

# Nut Splitters

HYDRAULIC

## 15 & 25 Ton Capacity

HYDRAULIC TOOLS

### HYDRAULIC NUT SPLITTERS – 15- & 25-TON CAPACITY

- "Dial-in" feature on HNS150 makes adjustment of splitter simple, without the worry of damaging the bolt
- Specially designed "tool steel" cutter blade penetrates the nut to the precise point where it cracks, stopping short of the bolt threads
- Nut splitter features a dramatically improved cutter blade with an 800% greater resistance to chipping and breaking over previous models

- All models feature a rugged one-piece cutting frame coupled to a heavy-duty hydraulic cylinder
- Compact size allows you to use it in confined areas where it will deliver enough force to split the toughest "fused" or rusted-on grade 2H nuts
- Simply split nut on one side, spin nut splitter 1/2 turn and make second cut on opposite side; nut separates into halves for easy removal



HNS150A



HNS150



HNS225

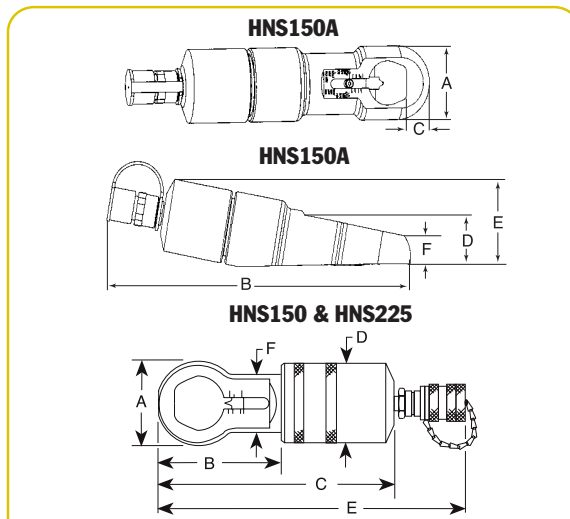

Align mark on cutter blade with scale.

Tool Model	HNS150 & HNS225						HEAD THICKNESS (mm)	REPLACEMENT BLADE	TOOL WEIGHT (kg)
	A	B	C	D	E	F			
HNS150	73	86	200	70	264	53	25,4	308840	3,7
HNS150A	77	361	27	54	94	30	25,4	351985	7,2
HNS225	108	153	366	99	C	82	38,1	308022	13,2

### CAPACITIES

Tool Model	5 (2 or A)	Nut Grade 9 (5 or B)	10 (8 or C)	12 (2 or H)
HNS150	1/2 - 1-1/2" (12,7-38,1mm) hex	1/2 - 1-1/2" (12,7-38,1mm) hex	1/2 - 1-5/16" (12,7-33mm) hex	1/2 - 1-1/8" (12,7-29mm) hex
HNS150A	1/2 - 1-1/2" (12,7-36mm) hex	1/2 - 1-1/2" (12,7-36mm) hex	1/2 - 1-5/16" (12,7-33mm) hex	1/2 - 1-1/8" (12,7-29mm) hex
HNS225	1-1/8 - 2-1/4" (29-57mm) hex	1-1/8 - 2-1/4" (54-57mm) hex	1-1/8 - 2-1/8" (29-55 mm) hex	1-1/8 - 1-11/16" (29-43mm) hex